



0110 D

Active
Studio Monitor

Installation and Operation



Safety Instructions

It is absolutely essential that you read these safety instructions carefully before connecting and using this K+H product. Your safety depends on it. Furthermore, failure to follow these instructions voids the warranty. To ensure safe operation for years to come, keep these instructions in a safe place for future reference. K+H has manufactured this product in accordance with IEC 92 (SEC) 39 standards, then tested and delivered it in safe operating condition. To maintain it in this condition, you must:

- observe all safety instructions,
- use the product only as described herein,
- have any maintenance, repairs, or modifications performed only by K+H or other authorized personnel, and
- ensure that the room in which you use this product is wired in accordance with the local electrical code.

Warning!

- When the interior of the cabinet is exposed, touching some parts can lead to an electric shock.
- If you need to gain access to the interior electronics of the unit, always disconnect the unit from any and all power sources first.
- Any repairs, maintenance, or other service of the unit when its interior compartment is exposed may only be performed safely (in accordance with VBG 4) by authorized technicians familiar with all the risks involved. Even in an unplugged state, a fully charged capacitor in the unit can zap the unsuspecting.
- Loudspeaker output jacks labeled with the IEC 417/5036 emblem (Fig. A, right) may be carrying dangerously high voltages. If your unit has this emblem, ensure that any connections to be made between these jacks and the speakers themselves are made before powering up the unit, and are done so only with manufacturer-approved interconnecting cables.
- If you need to replace any fuses, ensure that the replacements are of exactly the same type, value and voltage as the originals, as spelled out in the technical specifications at the rear of this manual.
- Do not use "repaired" fuses.
- If you do not have any fuses on hand of the specified size, type, and value, do not hot-wire the contacts in the holder by short-circuiting them.
- Certain areas of the cabinet, cover, and rear panel can achieve extreme temperatures and are therefore marked with a "HOT" label (Fig. B). Refrain from touching any heat sink or ventilation grille.
- High volume levels are known to cause permanent - i.e. irreversible - hearing damage, especially when listened to without sufficient breaks. The higher the levels, the more frequent and extended must be the breaks. Avoid standing too close to loudspeakers that are being driven at high levels. If you must be exposed to high sound pressure levels over an extended period of time, use hearing protection.



Fig. A



Fig. B

Mains Connection:

- This unit is designed for continuous operation.
- Ensure that the operating voltage of the unit matches that of the local mains current (AC line voltage).
- Always check before connecting the power cable to the mains socket that the power switch on the unit itself is set to off ("O").
- Use the power cable or power supply that came with the unit to connect to the mains socket (wall outlet).
- Power supply: a damaged power cable may not be repaired. Use a new cable.
- Avoid plugging the mains cable into a power strip that already has several other power-consuming devices connected to it.
- Avoid using extension cables. The unit must be connected to a mains socket close to it, and that socket should be freely accessible.

Installation:

- This product may only be placed on a stable, clean, horizontal surface.
- Do not expose this product to vibration.
- Do not operate this product anywhere near water or other liquids. Do not use it near a sink, swimming pool, bathtub, or in any damp room or area. Electrical shocks carried through water can kill. Do not place any beverages whatsoever on or near this product, as liquids can kill electronic components.
- Ensure sufficient ventilation around the product to allow for adequate heat dissipation, especially near the rear panel and the sides of the cabinet (minimum of 8 inches from the nearest wall). The unit may only be installed in a rack if measures are taken to ensure sufficient ventilation and if the mounting instructions of the manufacturer are followed. Do not block or cover any heat sink, fan, or vent.
- Do not place the product where it will be in the path of direct sunlight, and keep it safe distance away from radiators and other heaters of any kind.
- If you bring this product from a cold environment into a warm one (such as from a vehicle into a studio), it is quite possible that condensation will form inside the cabinet. Please allow the unit sufficient time for acclimatisation to room temperature (minimum thirty minutes) before connecting and powering up.
- To avoid accidents, do not use any accessory equipment with this product which is not approved by the manufacturer, particularly mounting accessories. Do not place this unit on any unstable platform, cart, stand or table. Should the unit fall, it can cause bodily injury to persons, or can be damaged itself.
- To protect this product from lightning damage during a thunderstorm or from power surges during an extended absence, disconnect the power cable from the wall outlet.

**Active
Studio Monitor**

Active Studio Monitor

KLEIN + HUMMEL O 110 D

Installation - Operation



Figure 1: Front view of the O 110 D



Figure 2: Rear panel of the O 110 D

Table of Contents:

Safety Instructions.....	2	1.6.3 Level ATT(ENUATOR).....	5
Table of Contents.....	3	1.6.4 INPUT SELECT Switch.....	5
1. Installation and Operation.....	4	1.6.5 Equalization.....	5
1.1 Operating Conditions.....	4	1.6.6 Ground Lift.....	6
1.2 Installation.....	4	1.7 Display Functions.....	6
1.3 Connection to Mains Current.....	4	1.7.1 Overload Protection.....	6
1.4 POWER Switch.....	4	1.8 Care of the Cabinet.....	7
1.5 Mains Power Fuse.....	4	2. Diagrams.....	7
1.6 Input / Room Compensation / Ground Lift.....	4	3. Warranty Information.....	9
1.6.1 XLR Input.....	4	4. EC Declaration of Conformity.....	9
1.6.2 BNC - Input.....	5	5. Compliance to FCC Rules.....	9
		6. Technical Specifications.....	10

1. Installation and Operation



It is absolutely essential that you read and observe the Safety Instructions on page 2 before connecting or using this device.

1.1 Operating Conditions

The K+H model O 110 D active studio monitor is intended for use over a range of ambient temperatures from +10° C to +40° C (+50° F to +104° F). During transport or storage, temperatures from -25° C to +70° C (-13° F to 158° F) are permissible.

1.2 Installation

The loudspeaker chassis used in the O 110 D are magnetically shielded, allowing these loudspeakers to be mounted side by side with a video or computer monitor without adversely affecting the screen. One of the finer features of the O 110 D active studio monitor is its unusually uniform off - axis directivity, which results in a very wide "sweet spot". Preferred placement of the cabinet is in the upright position, for the dispersion in the vertical plane was intentionally kept narrower than in the horizontal.

In certain cases, for example if there are hard, reflective surfaces both to the left and right of the loudspeakers, it would make sense to operate the loudspeakers on their side. The reduced horizontal directivity in this position would then be helpful in minimizing any phase cancellation caused by comb - filter effects.

When considering placement, please take into consideration the possibilities offered by both of the room compensation switches described in section 1.6.5.

On the back of the unit you will find two M8-style threaded bushings for use with various mounting options. These holes are labeled "Speaker mount option." The bushings will accommodate either the LH 32 wall bracket adapter or the LH 31 mounting bracket for use with additional mounting accessories.



The plastic screws that occupy these threaded holes from the factory may not be used for the actual mounting of a loudspeaker under any circumstances.

Please ensure that these threaded holes are always plugged so that the volume of air sealed within the cabinet may only pass through the precisely calculated bass - reflex openings.

1.3 Connection to Mains Power

Several versions of the O110D are available for different mains voltages. Please verify the label on the back side of the device is correct. If it becomes necessary to use a different mains-cable plug, pay attention to proper grounding when wiring a replacement plug.

1.4 POWER Switch

When you switch power on, there is a 7 second delay before the amplified signal is sent to the loudspeakers. This delay prevents the loud popping sounds that otherwise are generated by prior devices in the signal chain as they are switched on. You will find this arrangement particularly useful if your studio uses a master switch to power up all the equipment at once. When power on the O 110 D is turned off, on the other hand, or if there is a general power failure in the area, the signal flow to the speaker is immediately stopped, preventing any loud pops.

1.5 Mains Power Fuse

Should you ever need to replace the power fuse, please ensure (first of all that the unit is unplugged from the mains!) and that only the following type and value of fuse is used:

- For 230-240 volts AC: 1 A Slo-Blo (5 x 20 mm)
- For 117 volts AC: 2 A Slo-Blo (5 x 20 mm)
- For 100 volts AC: 2.5 A Slo-Blo (5 x 20 mm)

1.6 Input analog-digital / Level / Room Compensation / Ground Lift

1.6.1 XLR - INPUT

ANALOG / DIGITAL - AES/EBU

The sensitivity of the electronically balanced input is rated at +6 dBu (1.55 volts). The three - pole female XLR jack is wired in the standard manner (pin 1 = ground, pin 2 = +, pin 3 = negative). If you are connecting unbalanced sources, you will need to solder a bridge between pins 1 and 3:

unbalanced

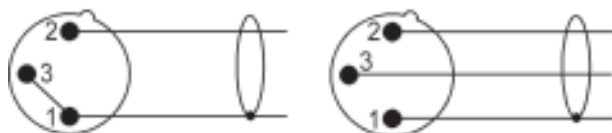

balanced

as seen from solder terminals of male XLR

Figure 3: Pin layout of input connector

In digital mode, this same XLR input accepts the digital signal according to the AES/EBU specification (110 Ohm balanced).

1.6.2 BNC - Input

DIGITAL INPUT / THROUGH

This digital input, configured as a 75-Ohm BNC connector, is intended to receive signal sources in S/P-DIF or AES 3id format. The incoming digital signal line requires **one** 75 -Ohm terminator at the very end, as the O 110 D has no internal termination.

The XLR input and the BNC input are wired in parallel across a transformer. The fact that the termination is wired externally allows you to make connections in a wide variety of ways:

1.6.2.1 Source 1x AES/EBU, monitors connected with each other via BNC cable

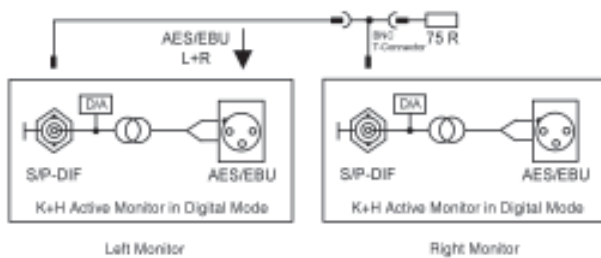

To obtain an output voltage of 1 Vpp at the BNC-output connector (with 75 - Ohm terminator), an input voltage of 5 Vpp at the AES/EBU input is required. This complies with the rules for AES/EBU level. If the input level varies, the output level does so accordingly.

1.6.2.2 Source 2x AES/EBU

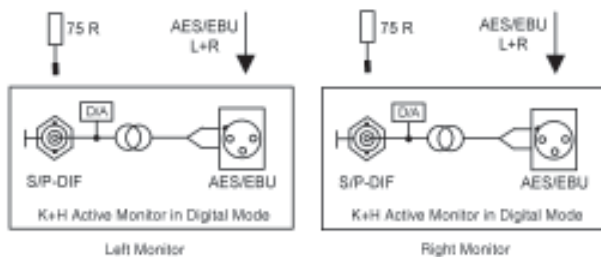

1.6.2.3 Source 1x S/P-DIF or 1x AES 3id, connection using two t - connectors

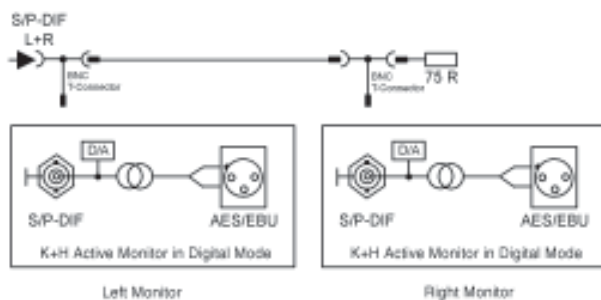

1.6.2.4 Source 2x S/P-DIF or 2x AES 3id

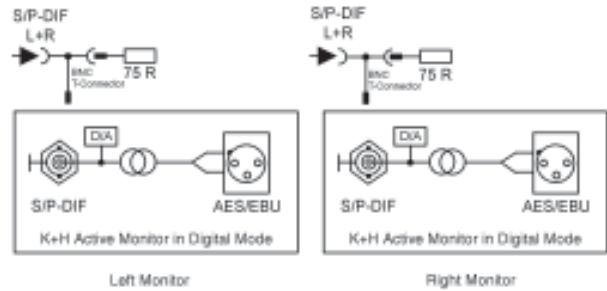

1.6.3 Level ATT(ENUATOR)

Directly beside the input XLR jack you will find the **ATTENUATOR** pot, which allows for smooth, gradual damping of the input signal by anywhere from 0 to 24 dB in both analog and digital modes.

1.6.4 INPUT SELECT switch

Use a screwdriver to change the position of this recessed switch in order to select analog or digital mode of operation. Since one digital input carries both stereo channels, the input selector has three additional positions for establishing how the monitors are assigned to the channels. This works as follows:

- Position A = Analog mode (XLR input)
- Position R = Digital mode right channel
- Position L = Digital mode left channel
- Position M = Digital mode mono (summed from both left and right channels)

Simultaneous operation from one analog and one digital source is not possible. At any given time you may connect only **one** type of source to the pair.

1.6.5 Equalization

1.6.5.1 BASS Switch

The four-position rotary switch labeled **BASS** (see Figure 2, Equalization section) serves to alter the frequency response of the loudspeaker to compensate for the overemphasis of low frequencies that may result from the specific location at which the speaker is placed within the room:

- Position 0 = free standing
- Position 1 = placement a short distance before a wall
- Position 2 = placement flat against a wall
- Position 3 = placement in a corner of the room

1.6.5.2 MID Switch

If the loudspeakers are placed on the meter bridge, a certain overemphasis in the midrange will typically

result. Next to the four-position switch for room compensation which we just described, there is another four-way rotary switch labeled **MID**. The four switch settings are intended for the following kinds of placement:

- Position 0 = free standing
- Position A = placement on a table top
- Position B = free standing on the meter bridge
- Position C = on the meter bridge between other equipment directly on either side, or built into a wall.

Note: Since it is not possible to list all possible combinations of speaker placement and room acoustics, we strongly recommend checking the switch settings acoustically or by measurement.

The frequency response curves of both equalizers are shown in Figure 12 in section 2, diagrams.

1.6.6 Ground Lift

Since the input is balanced, a ground loop hum will rarely occur. In special cases or if the source signal is unbalanced, it can become necessary to separate the signal ground from chassis ground. To do so, first unplug the mains cable from the mains socket, of course, then unscrew and remove the back panel, which has the amplifier electronics mounted directly to it. Figure 4 shows the amplifier circuit board below the XLR jack. The arrow is pointing to a jumper, which by default bridges the two pins. If you remove the jumper the signal ground is lifted from the chassis ground. Of course the chassis ground always remains connected to the protective earth conductor.

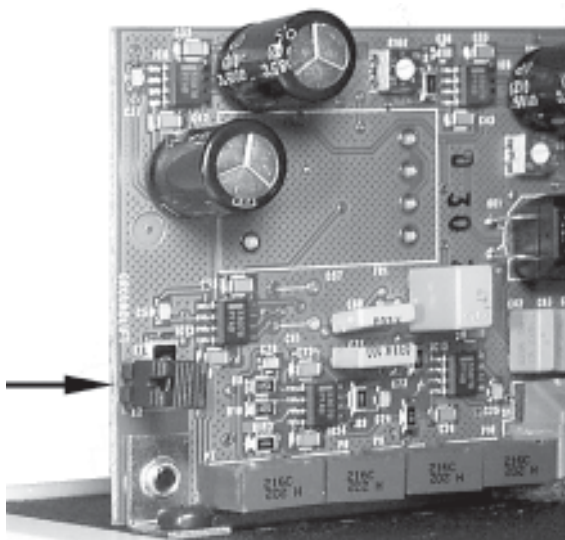

Figure 4: Ground Lift Connection

Warning!
The protective earth conductor must never be interrupted even for test purposes! This may be dangerous to life!



1.7 Display Functions

The illuminated K+H logo serves as a status display for the loudspeaker when the power switch is on and the fuse is intact:

- Continuous red: Normal operation, internal supply of power is in order
- Blinking red: Overload protection circuitry engaged

If the light is blinking, this indicates that the overload protection circuitry has been triggered. Among the things that can trigger it are the "scrubbing" of analog tape in cue - mode, extremely bass - heavy signals or the sine - wave signals that are used in performing measurements. The protection circuitry limits the output power of the amplifier to a level that is safe for the speaker. If the output level should drop as in one of these cases, check for the cause and, if necessary, reduce the monitoring level.

1.7.1 Overload Protection

As we just described above, the protection circuit limits the signal to safe levels. This occurs so gradually, that under certain circumstances you may not even notice that the protection circuitry has been triggered and the signal is being limited in dynamic range. But by moving an internal jumper you can change how this circuit responds, so that when it is activated, it will cause a clearly audible drop in level (**hard** position). To access this jumper, unplug the mains cable from the mains socket, unscrew and remove the rear panel,

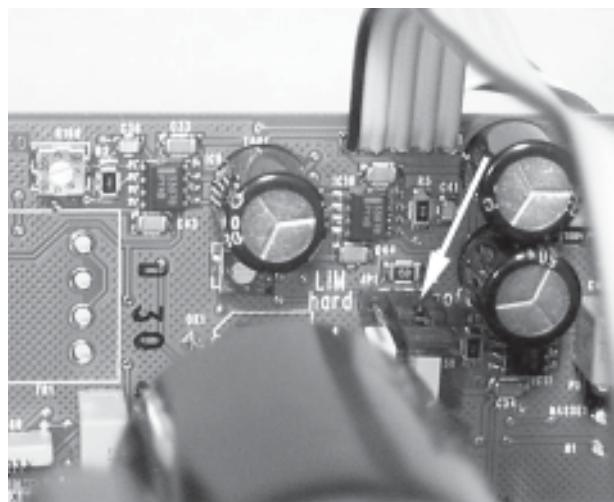

Figure 5: Jumper for Overload Protection Circuit

on the other side of which you will find the amplifier electronics. In Figure 5, the arrow points to the spot on the input circuit board where the jumper is located, next to the XLR input jack.

cabinet with care to avoid damaging the finish. To clean the cabinet, use a soft cloth with a mild cleaning agent only. Under no circumstances should you use chemical agents or any cleaners with abrasive action.

1.8 Care of the Cabinet

The cabinet housing of the K+H O 110 D active studio monitor has a painted finish. Handle the

2. Diagrams

The outstanding acoustic impression made by the O 110 is confirmed by measurements using today's most critical test methods. The test plots shown here

and on the next several pages are but a small sampling of these measurements.

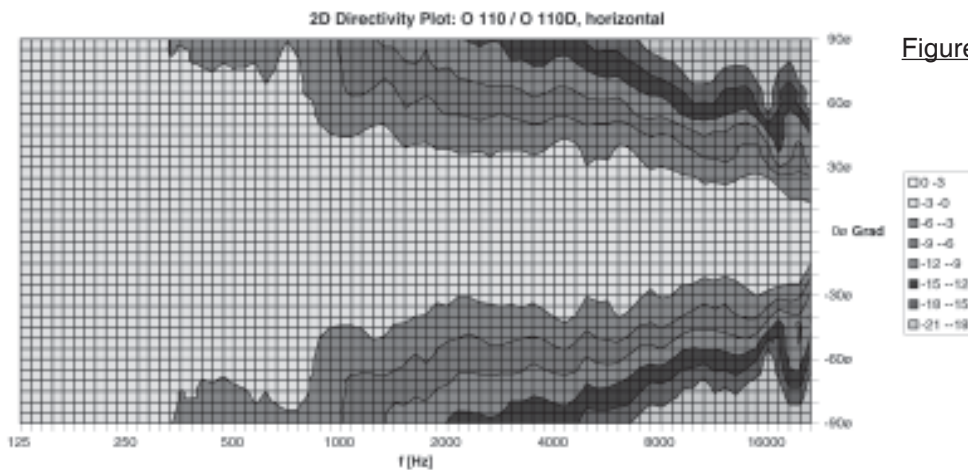

Figure 6: Horizontal Directivity

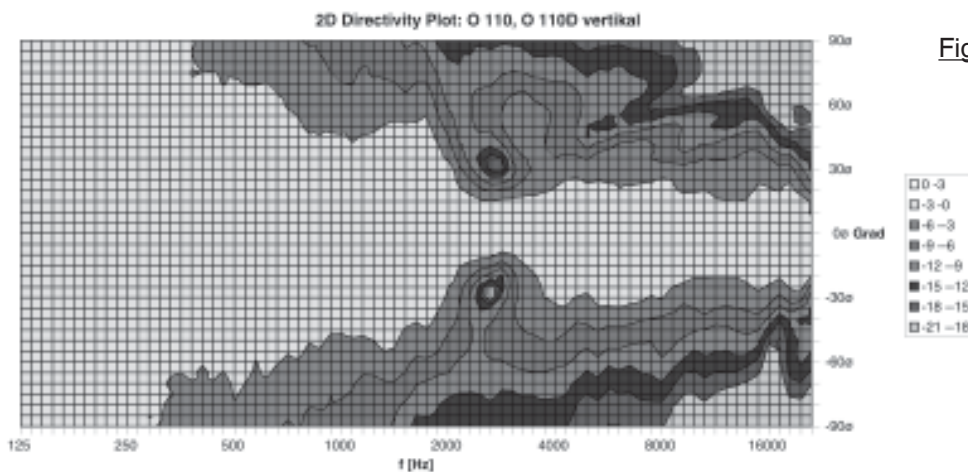

Figure 7: Vertical Directivity

Using the new material LRIM (**L**ow **R**esonance **I**ntegral **M**olding) allowed us to seamlessly integrate a waveguide into the baffle that is ideal for optimal dispersion. So an elliptical horn for the tweeter was

added. Thus came to be the dispersion pattern we mentioned earlier which is narrower vertically and broader horizontally, as is clearly evident in the test plots presented in Figures 6 and 7.

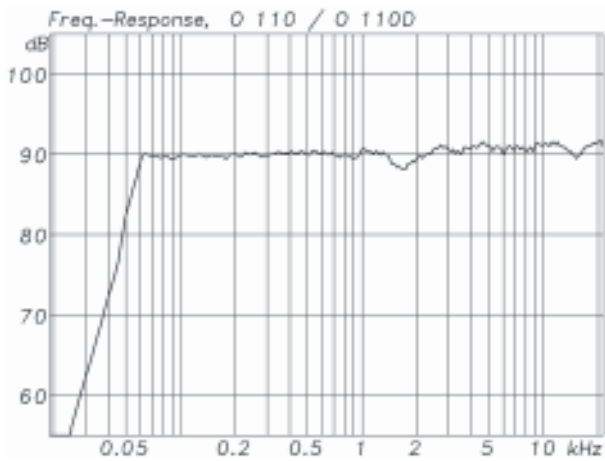

Figure 8: Frequency Response (free field)

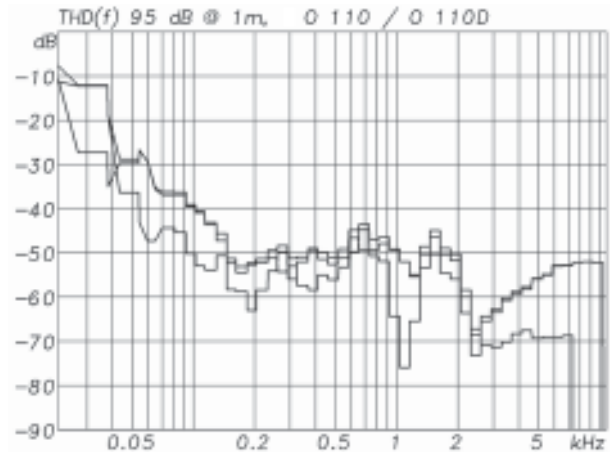

Figure 9: THD, 2 nd and 3 rd order distortion @ 95 dB/SPL and 1 m distance

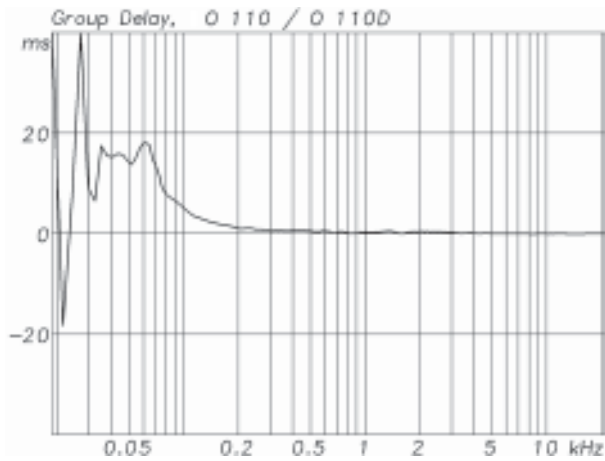

Figure 10: Group Delay

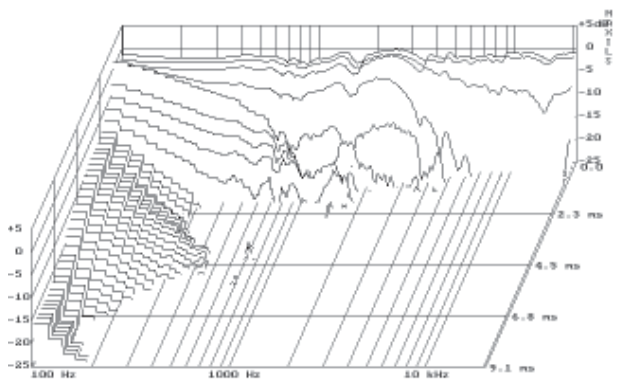

Figure 11: Cumulative Spectral Decay Plot

The loudspeaker's cumulative spectral decay plot indicates a very clean decay without any major resonances or standing waves being evident.

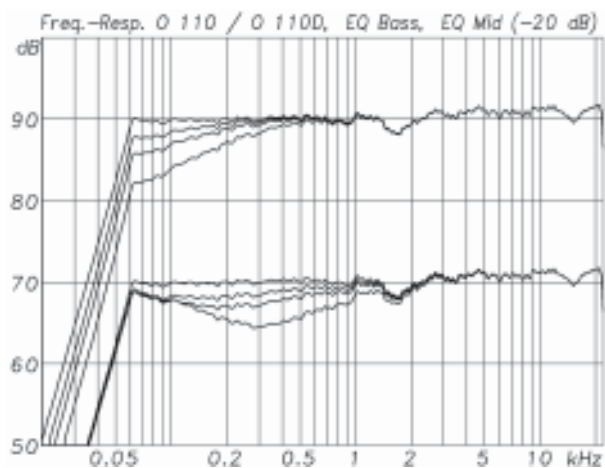

Figure 12: Equalization BASS (upper set of curves) and MID (lower set of curves)

3. Warranty Information

All K+H products undergo an extensive procedure of quality control testing before leaving the factory. Before semiconductors are mounted on the circuit board, they are subject to rigorous tests. Every single unit is guaranteed to match its technical specifications within strict predetermined tolerances.

Please store the original carton in a safe, dry place. If you should ever need warranty service, put the unit in its original packing material and carton together with a detailed description of the problem, and ship it (freight prepaid) to our distributor.

K+H warrants, that the product is free from any defects in both material and manufacturing and that it meets the specifications. A warranty case can only be acknowledged under condition that the complaint is filed to our distributor or to us in writing **within 8 days** after delivery or detection of the fault. Not covered under this warranty are damages due to inexpert packing and shipment, wear and tear, improper handling, installation, operation and maintenance.

The limitation period for warranty claims is described in the terms and conditions of K+H GmbH. Its our choice to repair, to supply a new product or to withdraw from the contract.

In the event warranty service is required, presentation of a warranty card will not be necessary. Proof of purchase date can be made by filing copies of appropriate documents (invoice, delivery note).

4. EC Declaration of Conformity

This equipment is in compliance with the essential requirements and other relevant provisions of Directives 89/336/EC and 73/23/EC. The declaration is available on the internet site at www.klein-hummel.com. Before putting the device into operation, please observe any respective country-specific regulations.

5. Compliance to FCC Rules

This device complies with part 15 of the FCC Rules and with RSS-210 of Industry Canada. Operation is subject to the following two conditions:

- This device may not cause harmful interference, and
- This device must accept any interference received, including interference that may cause undesired operation.

This equipment has been tested and found to comply with the limits for a Class B digital device, pursuant to part 15 of the FCC Rules. These limits are designed

to provide reasonable protection against harmful interference in a residential installation. This equipment generates, uses and can radiate radio frequency energy and, if not installed and used in accordance with the instructions, may cause harmful interference to radio communications. However, there is no guarantee that interference will not occur in a particular installation. If this equipment does cause harmful interference to radio or television reception, which can be determined by turning the equipment off and on, the user is encouraged to try to correct the interference by one or more of the following measures:

- Reorient or relocate the receiving antenna.
- Increase the separation between the equipment and receiver.
- Connect the equipment into an outlet on a circuit different from that to which the receiver is connected.
- Consult the dealer or an experienced radio/TV technician for help.

This class B digital apparatus complies with the Canadian ICES-003.

Changes or modifications to this equipment not expressly approved by Klein + Hummel may void the FCC authorization to operate this equipment.

6. Technical Specifications

O 110 D

Maximum SPL

in half space, 3% THD at 1 m distance
averaged between

107.7 dB/SPL
100 Hz and 6 kHz

Free field frequency response

58 Hz - 20 kHz \pm 2 dB

Self generated noise level at 10 cm

\leq 20 dB(A)

Total Harmonic Distortion

150 Hz and above @ 1 m

$<$ 0.5 % @ 90 dB/SPL

Directivity

Horizontal

\pm 40° (-6 dB)

Vertical

\pm 30° (-6 dB)

Electronics

Power amplifiers

Bass amplifier

50 W at 6 Ohm (THD \leq 0.1 %)

Treble amplifier

50 W at 6 Ohm (THD \leq 0.1 %)

Crossover section

Crossover frequency

2.5 kHz

Crossover slopes

24 dB / octave

Protection circuit

against overload of both drivers

Input analog

Impedance

14 kOhm (electronically balanced)

Sensitivity

+ 6 dBu

Volume control

continuously variable from 0...-24 dB

Common mode rejection ratio

\geq 50 dB @ 15 kHz

Digital inputs and outputs

XLR: AES/EBU

impedance 110 Ohms, transformer balanced, floating

BNC: S/P-DIF, AES 3id

75 Ohms, unbalanced

Terminator

75 Ohms for BNC jack (external, not included)

Sensitivity

- 12,5 dBFs

Volume control

continuously variable from 0...-24 dB

Switch Input Select

analog / digital left / digital mono / digital right

Digital converter

Resolution, type

24 bit DA, Delta - Sigma

Sampling rate

32 - 96 kHz

Equalization

4 position switch positioning on mixing console

0; -1.5; -3; -5 dB

4 position switch positioning on rear/side walls

0; -2.5; -5; -7.5 dB

Drivers

Bass

magnetically shielded

Treble

5.5" \varnothing , Composite - Sandwich - Diaphragm

Connectors

Mains

1" \varnothing , Titanium Fabric Dome Tweeter

Analog / digital inputs

3 - terminal Euro connector

Digital inputs / outputs

XLR connector 3-pin female

BNC

Power consumption

Idle

18 VA

Full power

70 VA

Mains

fixed 100, 120 or 230 V AC, 50/60 Hz

verify label on device

Dimensions (W x H x D)

170 x 267 x 190 mm (6.7" x 10.5" x 7.5")

Volume

8.6 liters (0.300 cubic feet)

Weight

5.0 kg (11 pounds)

Cabinet finish

enamel anthracite RAL 7021 or silver RAL 9006

Accessories

LH 31 mounting bracket

LH 28 tripod bushing (LH 31 mounting bracket required)

LH 29 TV - spigot (LH 31 mounting bracket required)

LH 27 ball clamp mount (LH 31 mounting bracket required)

LH 7 or LH 8 adaptor (LH 31 mounting bracket required)

LH 32 wall bracket

C 15 eyebolt

KG 30 ball clamp mount



K+H Vertriebs- und Entwicklungsgesellschaft mbH

30900 Wedemark, Germany

Phone +49 (5130) 58 48 0

Fax +49 (5130) 58 48 11

www.klein-hummel.com